

C. A. BRAND.  
Machine for Turning Axles.

No. 162,893.

Patented May 4, 1875.

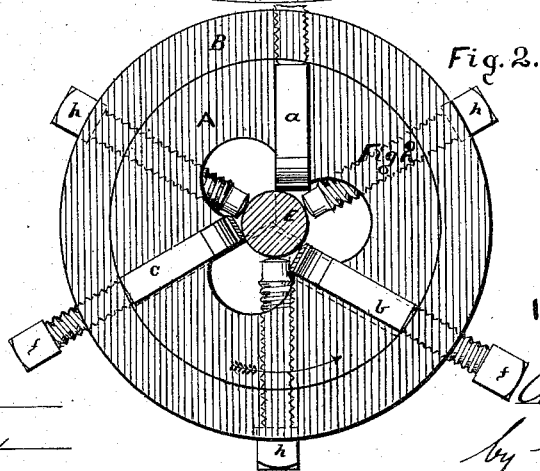
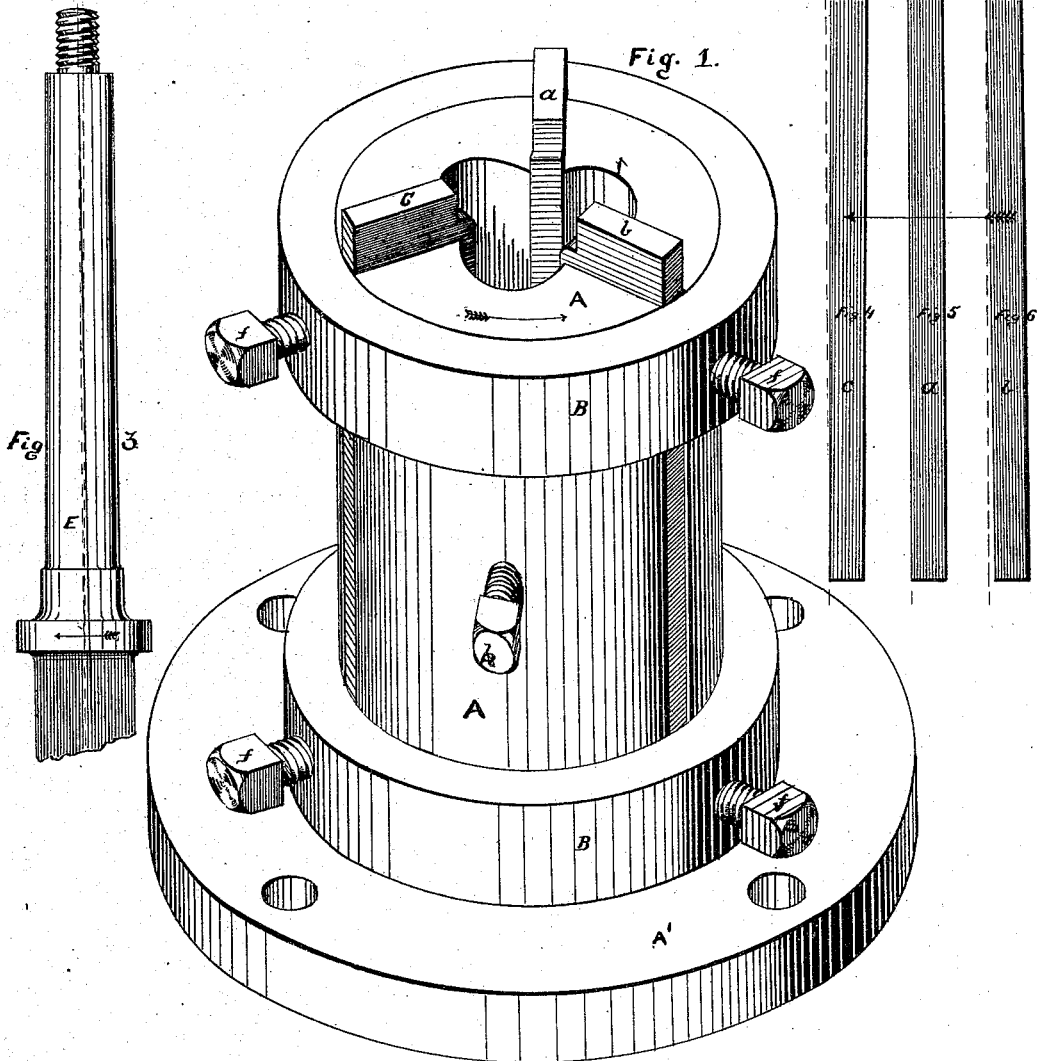

WITNESSES.

*Edwin Howard*  
*H. W. Harton*

INVENTOR.

*Charles A. Brand*  
*by E. H. W. J. Howard*  
*attor.*

# UNITED STATES PATENT OFFICE.

CHARLES A. BRAND, OF WILMINGTON, DELAWARE, ASSIGNOR OF ONE-HALF HIS RIGHT TO JAMES A. HOOPER, JR., OF BALTIMORE, MARYLAND.

## IMPROVEMENT IN MACHINES FOR TURNING AXLES.

Specification forming part of Letters Patent No. 162,893, dated May 4, 1875; application filed September 2, 1874.

*To all whom it may concern:*

Be it known that I, CHARLES A. BRAND, of the city of Wilmington, in the county of New Castle and State of Delaware, have invented certain new and useful Improvement in Machines for Turning Axles, of which the following is a specification; and I do hereby declare that in the same is contained a full, clear, and exact description of my said invention, reference being had to the accompanying drawing and to the letters of reference marked thereon.

My invention relates to a device or combination of devices by means of which axles are completely finished to a uniform size at one operation; and consists, broadly, in a revoluble head provided with a series of cutters arranged with their cutting-edges to extend radially from the center of the said revoluble head, each cutter occupying a different longitudinal position from the others, or varying with reference to the axis of the said revoluble head, for purposes hereinafter fully set forth and described.

In the description of my invention which follows due reference must be had to the accompanying drawing, forming a part of this specification, and in which—

Figure 1 is an isometrical view of my invention, with the cutters adjusted ready for use; and Fig. 2 a plan of the upper portion of the same. Fig. 3 is a view of a finished axle upon which the relative positions of the edges of the cutters are represented by one full and two dotted lines. Figs. 4, 5, and 6 are edge views of the cutters, showing their longitudinal positions.

Similar letters of reference indicate similar parts in all the figures, the arrows designating the direction taken by the several parts during a revolution of the head.

A is a hollow revoluble head, provided with the flange A', by means of which it is secured to the chuck-plate of the lathe. The head is slotted for the reception of the cutters *a*, *b*, and *c*, the slots extending radially from the periphery of the head to the interior or central opening in the same, and longitudinally from the face of the head to the flange A'.

By reference to Figs. 4, 5, and 6 it will be seen that the cutting-edge of the cutter *a*, when

viewed from the outer edge or back thereof, is parallel with the axis of the head, while those of the cutters *b* and *c*, as seen from similar positions, are inclined, and in opposite directions. In Figs. 4, 5, and 6 the dotted lines represent the central line of the head.

The cutting-edges of the cutters *b* and *c* correspond slightly to the form of a helix, being hollowed to compensate for their angular positions upon the axle, and to prevent the axle from being formed concave in the direction of its length. I do not, however, wish to be confined to the direction and degree of inclination of the cutters in the head, or to the number of cutters used, or be limited to the use of cutters formed of one piece of metal in the direction of their length, as such modifications would not affect the nature of the invention.

B B are loose collars or bands placed upon the head for the double purpose of strengthening the head and supplying material to hold the set-screws *f*. The screws *f* are used to set the cutters to their proper distances from the center of the head, and to sustain them while performing their office.

My object in placing the cutters as above described is to prevent what is technically termed "chattering," which causes the surface of the axle to become rough and unsuited to revolve in the box in the hub of the wheel. I have found by experience that it is impossible to make an axle smooth and free from the effects of chattering with the cutters arranged either all upon a line parallel with the axis of the head or inclined in the same direction and to the same extent. The set-screws *h* are designed to bear against the rough axle to steady it until operated upon by the cutters. In Fig. 2 the axle is represented by E, and shown in this position.

The operation of turning axles by means of my invention is as follows: The head having been secured to the chuck-plate of the lathe, one end of the rough axle is inserted in the central cavity of the head, and the sliding center of the lathe or some other suitable feeding apparatus applied to the other. The axle is thus forced into the revolving head, a clamp being used to prevent its turning. The cutters being set to the proper diameter, the axle is com-

pleted as soon as it has passed a certain distance into the head, each completed axle being a counterpart of the others.

From the foregoing description it will be seen that axles can be accurately finished so as to be interchangeable with much greater rapidity and at a less expense than by the old method of first centering the axles and then turning them in the ordinary manner in a lathe.

Having thus described my invention, what I claim as new, and desire to secure by Letters Patent of the United States, is—

1. In a machine for turning axles, the hol-

low revoluble head A, with flange A', in combination with the cutters *a*, *b*, and *c*, arranged with reference to the axis of the head A, as described, substantially as set forth.

2. The head A, in combination with the collars B and set-screws *f* and *h*, substantially as and for the purpose set forth.

In testimony whereof I have hereto subscribed my name this 8th day of August, A. D. 1874.

CHAS. A. BRAND.

Witnesses:

EDMUND B. FRAZER,  
JAMES A. HOOPER, Jr.